



## **ON-FLOW ENERGY RECOVERY SYSTEM**

### **WPX-(Work Pressure Exchanger) Energy Recovery System**

The **WPX** product was originally developed for the highest in efficiency and easy operation and combines the following impressive attributes:

- Most efficient Energy Recovery device ever developed with efficiency up to 98%.
- Able to operate under any R/O typical variations in Flow and Pressure without adjustments.
- Flat efficiency curve over a wide performance range.
- Easy to maintain with standard tools. Down time as little as 4 hours per year.
- Designed for a 25-year lifetime in Super Duplex SS and Fiberglass Materials.
- The WPX PLC. ensures simple integration into any Plant Control Philosophy as well as control of over-flush and mixing.

### **Efficiency**

To evaluate the real overall efficiency of a Direct Transfer Pressure Exchange Energy Recovery Devices, two issues need to be considered:

- Equipment efficiency
- Equipment losses with an Impact on the R/O process
- Mixing between feed water and brine: Below 1,5 % Volumetric
- Over flush: Can be adjusted to 0 %

### **Further Advantages**

- Discharge against backpressure possible but not mandatory for easy brine evacuation.
- Slow moving equipment speed of around 1m/s.
- Standard Noise level below 80 dBA.
- Specially Designed Control Valve ensures smooth system operation
- ON-Flow Engineer's have a wealth of SWRO experience and are available to advise and assist at the design and construction stage, turnkey.
- The robust and proven design is resistant against particles in the water (such as sand etc.)
- WPX field experience since 1989 in highly water dependent locations.

**WPX (Work Pressure Exchanger) Energy Recovery** process involves pressurizing seawater, and depressurizing the concentrated reject brine. Reciprocating cylinders and computerized valve control system takes in seawater and transfers the energy from the brine reject to the seawater. The **WPX** system is highly efficient, leading to much higher energy recovery levels than previously possible.

**Pressure exchanger** technologies are shattering SWRO design barriers and yielding seawater power consumption figures that were previously unthinkable. The combination of designing at lower flux rates and conversion rates and using high flow, higher efficient main high pressure pumps makes it possible today to produce fresh water from the sea at around 1.7 kWh/m<sup>3</sup>. This represents a 15% reduction from just one year ago, when it was published for the first time that water could be produced for 2.0 kWh/m<sup>3</sup>.



With the new development of Nano-designed R/O membranes that can produce good quality water at 45 bar and 45% conversion rates these systems will be able to reach 1.5 kWh/m<sup>3</sup> or lower. The R/O system parameters were generated using Hydranautics RODESIGN32, 32,070 TDS ASTM seawater feed @ 25C, SWC3 membranes, 7 elements per vessel, 0 years. 8 gfd and 45% recovery design point. 89% and 96% efficient main high-pressure pump and motor, 87% and 95% efficient PX booster pump and motor. kWh/m<sup>3</sup> power figures are for the R/O process portion of the system only and do not include an allowance for the seawater supply pump.

**SEAWATER  
R/O FLOW DIAGRAM  
with  
WPX ENERGY RECOVERY UNIT**

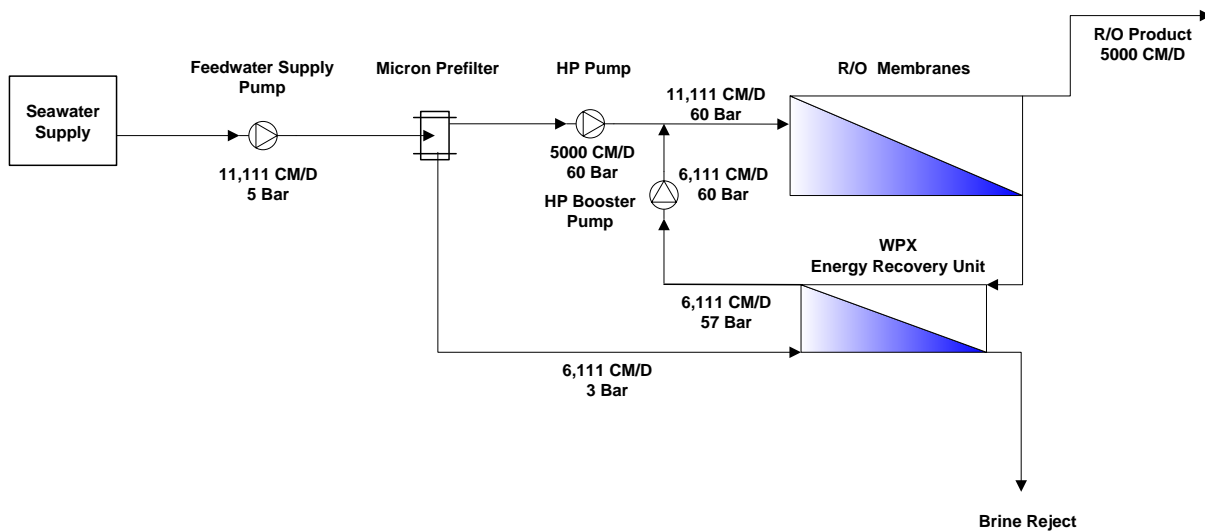

**ON-FLOW LLC**

455 East Yale Loop  
Irvine CA 92614  
USA

Phone: +1- Fax: +1-949-733-8099

Email:  
[onflowusa@gmail.com](mailto:onflowusa@gmail.com)

Web:  
[www.on-flow.com](http://www.on-flow.com)